



# Point Spring & Driveshaft Co.

Since 1926

**PARTS • SERVICE • EXPERIENCE • SOLUTIONS**



## Bendix® EnduraSure® Spring Brakes

### Two Great Options for Your Fleet's Needs

Choose between standard or sealed Bendix® EnduraSure® spring brakes – both deliver durability, long service life, and lower total cost of ownership.

#### EnduraSure®-Pro Spring Brakes (Sealed)

*Designed to help protect against contamination*

- Helps address the #1 cause of spring brake failure: broken power springs
- Lightweight design
- Warranty: 7-year (ADB), 6-year (drum)

#### EnduraSure® Spring Brakes (Non-Sealed)

*Lightweight durability with long spring life*

- More than 3X the power spring life of competitive non-sealed chambers
- Lightest T-30/30 in the industry
- Warranty: 4-year



Popular Part Numbers	
<b>Air Disc Brakes</b>	K132352 EPRO1824STD
<b>Drum Brakes (Trailers)</b>	NT3030STD-78 EPRO3030STD-78 NT3030STD-120 EPRO3030STD-120
<b>Drum Brakes (Tractors)</b>	NT3030ELS-WC EPRO3030ELS-WC

**Engineered for reliable fleet performance.**

Available for purchase through your nearest Point Spring & Driveshaft Co.!

[www.pointspring.com](http://www.pointspring.com)

Promotional pricing valid 6/1/2026 - 8/31/2026





# CHELSEA<sup>®</sup> 810 SERIES

## PTO for Ford 8-Bolt 10R140 Transmission

Parker Chelsea has made significant improvements to the 810 Series Power Take-off for the 8-Bolt version of the 10R140 transmission. The same patented noise mitigating design used in the industry leading 210 Series has been incorporated into the 810 Series. Unlike our competitors, the 810 Series offers multiple speed ratios and output options to better serve your many application requirements.

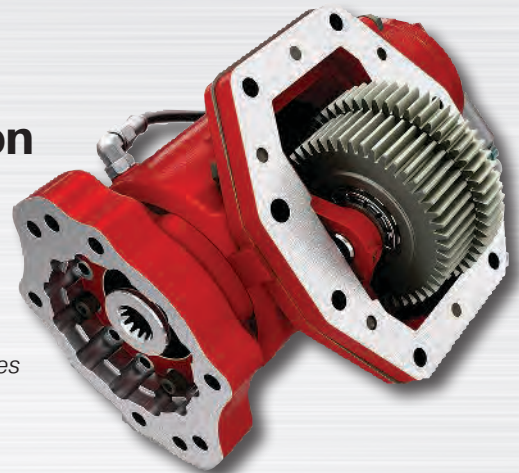

810 Series

### Applications:

- Refuse Trucks
- Utility Trucks
- Dump Trucks
- Tow and Recovery Trucks
- Fire and Rescue Trucks
- Snow and Ice Trucks
- Service Trucks

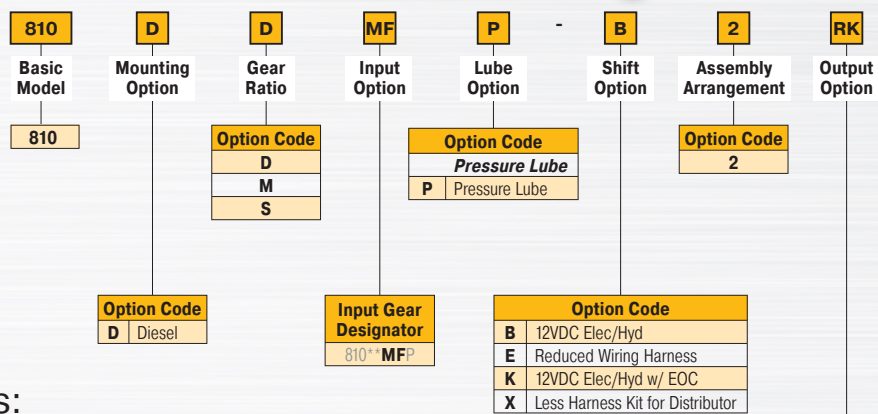

### Product Features and Benefits:

- Patented noise mitigation
- Common pump mount and drive line options
- Multiple ratio and output options
- SmartStart Technology to minimize the initial torque spike at engagement
- Proven Parker Chelsea durability
- Power-dense design

Option Code	
<b>Driveline Output</b>	
<b>SD</b>	SmartStart Standard Shaft (1-1/4" - 5/16" Key)
<b>SV</b>	SmartStart 1410 Series Companion Flange
<b>Pump Mount</b>	
<b>RF</b>	Rotatable SAE B 2 or 4-Bolt Flange, SAE BB Shaft (1" - 15T)
<b>RK</b>	Rotatable SAE B 2 or 4-Bolt Flange, SAE B Shaft (7/8" - 13T)
<b>RP</b>	Rotatable SAE A 2-Bolt Flange, SAE B Shaft (7/8" - 13T)

U.S. Pat. No. 12,366,289



Specifications Chart	Approximate Weight: 62.5 lbs. [28.35 kg]		
	810*D	810*M	810*S
Intermittent & Continuous Torque Rating (lb-ft) [N-m]	250 [339]	250 [339]	195 [264]
HP Rating for Intermittent & Continuous Duty			
At 500 RPM of Output Shaft (HP) [kW]	24 [18]	24 [18]	19 [14]
At 1000 RPM of Output Shaft (HP) [kW]	48 [36]	48 [36]	37 [28]



THE DRIVELINE EXPERTS

## NEW PRODUCT RELEASE!

# ShaftSwap<sup>®</sup> Interaxle Driveshafts

- An economic alternative to stocking multiple Interaxle driveshaft assemblies.
- Made in the U.S.A.
- Designed, engineered, and manufactured to industry OEM standards
- Improves customer satisfaction by minimizing downtime



Style 3

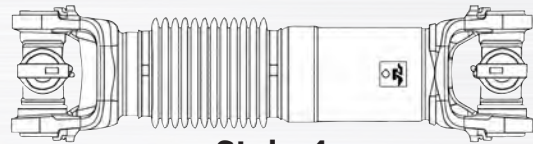

Style 4

STYLE	PART#	SERIES	ADDITIONAL DETAILS	PRICE
3	N170-IAD-1747	N170	Allows for 5.90" travel 17.47" collapsed length to 23.37" extended length	<b>1,135.99</b>
4	N170-IAD-2012	N170	Allows for 4.33" travel 20.12" collapsed length to 24.45" extended length Includes 5.184" of 4.73" X .197 tube welded to stub shaft and weld yoke	<b>1,135.99</b>
4	N170-IAD-2200	N170	Allows for 4.33" travel 22.00" collapsed length to 26.33" extended length Includes 5.184" of 4.73" X .197 tube welded to stub shaft and weld yoke	<b>1,135.99</b>
4	N170-IAD-2400	N170	Allows for 6.33" travel 24.00" collapsed length to 28.33" extended length Includes 7.2" of 4.73" X .197 tube welded to stub shaft and weld yoke	<b>1,164.99</b>
4	N170-IAD-2642	N170	Allows for 4.33" travel 26.42" collapsed length to 30.75" extended length Includes 10.29" of 4.73" X .197 tube welded to stub shaft and weld yoke	<b>1,164.99</b>



Point Spring & Driveshaft Co.

Since 1926



**FREIGHTLINER** 2011-2020 CASCADIA 125

**5405**  
OE# 22-65771-000  
- Clutch: 8 groove, 163.5mm  
- Head: Pad Type  
- Mount: Direct  
- Denso 10S15C

**SUPER HEAVY DUTY**

**1634**  
OE# VCCT1000898P  
- Hose Side  
In: #8 Stat Seal  
Out: #12 Stat Seal  
- Evaporator Suction Side  
In: #8 Stat Seal  
Out: #12 Stat Seal  
- Rating: 1-1/2 ton  
- Superheat 6.3

**7585**  
OE# A22-63633-000  
- Size: 4" x 7"  
- Pad Fittings

**FREIGHTLINER** 2019-CURRENT CASCADIA 126

**5405**  
OE# 22-65771-000  
- Clutch: 8 groove, 163.5mm  
- Head: Pad Type  
- Mount: Direct  
- Denso 10S15C

**SUPER HEAVY DUTY**

**16116**  
OE# BOAGH882001  
- Hose Side  
In: #8 Stat Seal  
Out: #12 Stat Seal  
- Evaporator Suction Side  
In: #8 Stat Seal  
Out: #10 Stat Seal  
- Rating: 1-1/2 ton  
- Main Unit

**7638**  
OE# A22-77123-000  
- Size: 4" x 7"  
- Pad Fittings

**MACK** ANTHEM

**54732**  
OE# 82768117  
- Clutch: 8 groove, 180mm  
- Head: 4670  
- Mount: Direct  
- Sanden #4732

**SEALED SUPER HEAVY DUTY**

**16125**  
OE# 82795831  
- Hose Side  
In: #6 Deep Bead  
Out: #10 Deep Bead  
- Evaporator Suction Side  
In: #8  
Out: #10  
- Rating: 1-1/2 ton  
- Main Unit

**7635**  
OE# 82771584  
- Size: 3" x 9"  
- Pad Type  
- Moisture Indicator

# AirSource®

**VOLVO** 2011-2019 VHD, VN

**5404**  
OE# 20721587  
- Clutch: 8 groove, 180mm  
- Head: WV  
- Mount: Direct  
- Sanden #4326

**SEALED SUPER HEAVY DUTY**

**1684**  
OE# 85120289  
- Hose Side  
In: #6 Female O'ring  
Out: #12 Female O'ring  
- Evaporator Suction Side  
In: #8 Female O'ring  
Out: #12 Female O'ring

**7159**  
OE# 82781559  
- Size: 3" x 9"  
- In: 3/8" Male O'ring  
- Out: 3/8" Male O'ring  
- Top Sight Glass  
- Top Schrader Valve  
- Moisture Indicator  
- Pressure Relief Valve

*MEI Corporation Offers a Full Line of A/C Products. Refer to our catalog for more complete Application, Specification, and Interchange Information.*

**KENWORTH** 2014-2021 T600, T680, T800, T880

**54148**  
OE# F69-1018  
- Clutch: 8 groove, 130mm  
- Head: 4577  
- Mount: Direct  
- Sanden #4006, 4146

**SUPER HEAVY DUTY**

**1644**  
- Hose Side  
In: #6 Female O'ring  
Out: #10 Female O'ring  
- Evaporator Suction Side  
In: #8 Female O'ring  
Out: #8 Female O'ring  
- Rating: 2 ton  
- M10, M12 Ports

**7387**  
OE# K251-571  
- Size: 3" x 10"  
- In: 3/8" Female O'ring  
- Out: 3/8" Male O'ring  
- Side Sight Glass  
- Moisture Indicator

**PETERBILT** 2010-2023 579

**54106**  
- Clutch: 6 groove, 125mm  
- Head: 4577  
- Mount: Direct  
- Sanden #4106

**SEALED SUPER HEAVY DUTY**

**1694**  
- Hose Side  
In: #6 Sealing Washer  
Out: #12 Sealing Washer  
- Evaporator Suction Side  
In: #8 Sealing Washer  
Out: #10 Sealing Washer  
- Rating: 2 ton

**7413**  
OE# F37-1017-200  
- Size: 3" x 10-5/8"  
- Pad Fittings #8

**INTERNATIONAL** 2016-2017 PROSTAR

**5347S**  
OE# 3628699-C2  
- Clutch: 6 groove, 125mm  
- Head: GWA  
- Mount: Direct  
- Sanden #4570

**SUPER HEAVY DUTY**

**1690**  
OE# 3857948-C2  
- Hose Side  
In: #8 Female O'ring  
Out: #10 Female O'ring  
- Evaporator Suction Side  
In: #8 Female O'ring  
Out: #10 Female O'ring  
- Rating: 2 ton

**7421**  
OE# 3839360-C92  
- Accumulator  
- w/o Aux AC  
- 2 Ports

**INTERNATIONAL** 2018-CURRENT LT

**54585**  
OE# 3863068-C1  
- Clutch: 6 groove, 119mm  
- Head: 4347  
- Mount: Direct  
- Sanden #4585

**16128**  
OE# 2516574-C91  
- Hose Side  
In: #8 Female O'ring  
Out: #12 Female O'ring  
- Evaporator Suction Side  
In: #8 Female O'ring  
Out: #12 Female O'ring  
- Rating: 2 ton

**6457**  
OE# 2519451C91  
- Condenser  
- Height: 20"  
- Length: 33 1/4"  
- Thickness: 5/8"  
- Pad Type Fitting

Copyright © All Rights Reserved

**Available for purchase through your nearest Point Spring & Driveshaft Co.!**





## DIESEL EXHAUST FLUID HEADERS

- Field-Tested Reliability & Performance
- Built to Last & Withstand ALL Conditions
- OE-Grade Quality, Aftermarket Price
- Faster Access, Less Downtime
- Best-In-Class Sensor Technology



## DIESEL EXHAUST FLUID PUMPS

- Matches Fit & Function of the Original Pump
- Plug-and Play Replacement
- Durable Components, Quality Materials
- Extensive Testing for Long Service Life
- OE-Grade Function at Aftermarket Price



## THE MOST COMPREHENSIVE AFTERTREATMENT PROGRAM IN THE AFTERMARKET

### THE HEAVY DUTY PARTNER™

#### PRODUCT DETAILS - HEADERS

DAYTON #	APPLICATION SUMMARY	PRIMARY INTERCHANGES
904-7358	2017-10 Blue Bird, Cummins	10027844   10035950   10056545
904-7359	2024-18 Blue Bird, Cummins	10049766   10060598   10071997
904-7346	2024-14 Thomas Built, Cummins	04-36002-000   04-37384-000   04-37613-000
904-7347	2023-14 Freightliner, Thomas Built, Cummins	04-36003-000   04-37385-000   04-37614-000
904-7349	2024-17 Freightliner, Western Star, Cummins	04-35959-000   04-35959-001   04-35959-002
904-7353	2024-17 Freightliner, Western Star, Cummins	04-35649-000   04-35649-001   04-35649-002
904-7354	2017 Freightliner, Cummins	04-31353-003   04-31353-006   04-35960-000
904-7355	2020-14 Freightliner, Western Star, Detroit Diesel	04-30798-000   04-31677-000
904-7350	2022-15 Paccar, Cummins	Q21-6127-001   Q21-6167-001   Q21-6170-001
904-7351	2022-15 Paccar, Cummins	Q21-6127-002   Q21-6167-002   Q21-6170-002
904-7352	2024-14 Paccar, Cummins	Q21-6167-004   Q21-6170-003   Q21-6170-004
904-7356	2024-14 Volvo, Mack	22278207   24382877
904-7357	2022-14 Volvo, Mack	23045836   23539939   24383068

#### PRODUCT DETAILS - PUMPS

DAYTON #	APPLICATION SUMMARY	PRIMARY INTERCHANGES	VOLTAGE
924-5954	2014-12 Cummins ISB 6.7, ISX 15.0	2871879   4387304	12 V
924-5955	2014-12 Cummins ISB 6.7, ISX 15.0	4387305NX   4387305RX   5418806RX	24 V
924-5956	2018-15 Cummins ISL 8.9, ISX 11.9, ISX 15.0	4387657   A028Y792	12 V
924-5957	2018-15 Cummins ISL 8.9, ISX 11.9, ISX 15.0	4387658   5511745RX	24 V
924-5962	2018-14 Isuzu NPR, Reach	8982688110   S17H0E0012	12 V
924-5963	2020-14 Mack MP8, Volvo D13	21576178   22390377   23753841	24 V
924-5964	2022-13 Mack MP8, Volvo D13	22851853   21647139	12 V
924-5966	2026-11 Mack/Volvo w/MP7, MP8, D11, D13 Engines	85003865   85031447	12 V

Get vehicle applications and technical details at [daytonparts.com](http://daytonparts.com)

Dayton Parts is a company of Dorman Products, Inc. | Dayton Parts® Customer Service: 1-800-233-0299 | Tech Line: 1-800-822-2042

©2026 No reproduction in whole or in part without prior written approval.



**Point Spring & Driveshaft Co.**

Since 1926

# MAKE-SPECIFIC MOLDED FLOOR MAT SETS

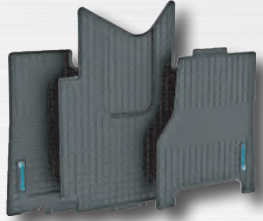

**562.FM46105**  
Freightliner



**562.FM55101MS**  
International

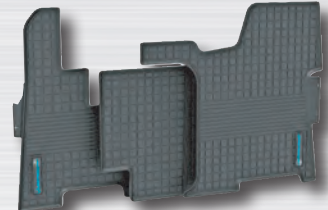

**562.FM75104**  
Peterbilt



**562.FM62101MS**  
Mack



**562.FM59101**  
Kenworth

Part #	Make	Application
562.FM46101	Freightliner	'08-'16 Cascadia P3
562.FM46102	Freightliner	'18-'26 Cascadia P4 116/126, Auto Transmission
562.FM46102MS	Freightliner	'18-'26 Cascadia P4 116/126 Auto Transmission, Western Star 47X/49X Auto Transmission
562.FM46104MS	Freightliner	M2-106/M2-112/108SD/114SD Except Full Width Bench Seat or National Brand Air Driver Seat
562.FM46105	Freightliner	Columbia C112/CL120, Century CST112/CST120, Coronado CC114/CC122/CC132 Auto/Manual
562.FM55101	International	LT Series
562.FM55101MS	International	ProStar w/AT, LoneStar w/AT,LT625 w/AT, RH613 w/AT, HX515/HX615, HX520/HX620 w/AT, Auto Transmission
562.FM55102MS	International	41/42/43/4400, 73/74/7500, DuraStar 41/43/4400, WorkStar 73/74/75/8500, TranStar 8500, MV60H/MV607
562.FM59101	Kenworth	T600, T660, T800, W900
562.FM59101MS	Kenworth	T440, T470, T600, T660, T800, W900 w/Standard Day Cab, Manual Transmission, Suspended Throttle Pedal
562.FM59102MS	Kenworth	Kenworth T680, T880 Manual Transmission, without Battery Box under Passenger Seat
562.FM59102MS	Peterbilt	Peterbilt 567, 579 Manual Transmission, without Battery Box under Passenger Seat
562.FM75101	Peterbilt	Early 357, 375, 377, 378, 379
562.FM75101UMS	Peterbilt	Early 357, 377, 378, 379, 385
562.FM75103	Peterbilt	Later 357, 375, 377, 378, 379
562.FM75104	Peterbilt	386, 365/367, 384/388, 389, Manual Transmission
562.FM75104MS	Peterbilt	386, 365/367, 384/388, 389, Manual Transmission, without Battery Box under Passenger Seat
562.FM75105	Peterbilt	567, 579 Automatic and Manual Transmissions, Manual Requires Cutting for Shifter
562.FM62101MS	Mack	Granite, Pinnacle, Anthem
562.FM96101	Volvo	VNL, VT
562.FM96101MS	Volvo	VNL, VT Auto Transmission

Promotional pricing valid 6/1/2026 - 8/31/2026

## POINT SPRING & DRIVESHAFT CO. LOCATIONS

**NEVILLE ISLAND, PA**  
7309 Grand Avenue  
Neville Island, PA 15225  
Ph: 412-264-6714  
Fx: 412-264-6722  
(800) 837-4713

**NEW CASTLE, PA**  
1001 Harbor Street  
New Castle, PA 16101  
Ph: 724-658-9076  
Fx: 724-658-8746  
(800) 837-8713

**TROY, PA**  
68 Canton Street  
Troy, PA 16947  
Ph: 570-297-5555  
Fx: 570-297-5510  
(855) 297-6380

**SARVER, PA**  
555 North Pike Road  
Sarver, PA 16055  
Ph: 724-352-3340  
Fx: 724-352-5311

**INDIANA, PA**  
1849 South Sixth  
Street Suite 5  
Indiana, PA 15701  
Ph: 724-463-3710

**GREENSBURG, PA**  
1967 Route 66  
Greensburg, PA 15601  
Ph: 724-834-0750  
Fx: 724-834-8747  
(800) 837-9713

**MEADVILLE, PA**  
11377 Mercer Pike  
Meadville, PA 16335  
Ph: 814-724-7746  
Fx: 814-724-7747  
(800) 724-7751

**CLEARFIELD, PA**  
1729 Industrial Park Rd.  
P.O. Box 1206  
Clearfield, PA 16830  
Ph: 814-765-9684  
Fx: 814-765-1577  
(800) 252-3585

**FAIRMONT, WV**  
274 Van Kirk Drive  
Fairmont, WV 26554  
Ph: 304-534-3306  
Fx: 304-534-5079  
(800) 837-1713

**AKRON, OH**  
1250 Triplett Blvd.  
Akron, OH 44306  
Ph: 330-724-1111  
Fx: 330-724-1895  
(800) 826-0673



**Point Spring & Driveshaft Co.**  
Since 1926

follow us on social media



Point Spring & Driveshaft Co.



@Pointspring1926